

A Hybrid Approach for Modeling Complex Antenna Systems on Vehicular Platforms

Werner Thiel^{1,3}, Linda P.B. Katehi² and Kazem Sabet³

¹University of Michigan, Ann Arbor, MI 48109, USA

²Schools of Engineering, Purdue University, West Lafayette, IN 47907, USA

³EMAG Technologies, Inc., Ann Arbor, MI 48108, USA

Abstract The use of multi-antenna systems on vehicular platforms, for the implementation of ad-hoc wireless network architectures, is typically hampered by the problem of co-site interference between transceivers loading neighboring radiating elements and the impact of the platform on the radiation pattern. This paper presents a rigorous, full-wave analysis of effects pertinent to vehicular multi-antenna system performance, based on a hybrid time/frequency domain analysis that combines the method of moments (MoM) with the finite difference time-domain method (FDTD). For the fast solution of such problems, MPI-based parallelization strategies are developed. Applications where the combined MoM and FDTD simulation of multi-antenna systems sheds light to the serious impact of mutual transceiver interference on wireless network operation are provided.

I. INTRODUCTION

A variety of commercial and military radio network architectures adopt multi-antenna systems due to their simplicity. In particular, transmit-receive modules mounted on vehicular platforms are widely encountered in ad-hoc network configurations of VHF military radio and are also considered for future generations of mobile wireless systems. However, the concurrent operation of individual receive-transmit modules, often gives rise to co-site interference side effects, such as desensitization, inter- and cross-modulation that eventually corrupt the overall system performance [1, 2]. Further, since vehicles carry several complex antennas for different frequency bands the radiation patterns regarding the beam width and the side lobe level are often affected significantly by neighboring antennas and especially by the shape of the platform.

In the past, modeling of such effects relied on measurement data, since the proximity of the interfering radiators and the presence of complex scatterers (such as the platforms themselves) within the near field of those, prohibits the use of Friis formula for the straightforward computation of interference power levels [3]. Furthermore, high performance phased arrays are mostly designed for free space applications or an operation above perfect conducting ground and in addition, for many full wave techniques approximations and assumptions, e.g. inappropriate boundary conditions, may apply. For ex-

ample, the method of moments (MoM) [4, 5] is limited by finding a Green's function for the specific problem. As a consequence, most of the full wave techniques cannot provide a solution to the entire problem and are highly inefficient and erroneous in this case. Nevertheless, the advances in differential methods for computational electromagnetics, and the exploitation of parallelization techniques have made possible the full-wave simulation of complex large-scale systems including multiple platforms.

In this work, we focus on the characterization of the crosstalk between mutually coupled antennas and study intensively the impact of vehicular platforms on the radiation pattern by applying a hybrid MoM/FDTD method. A short overview of the concept of the utilized hybrid technique is given in section II. As an example, the radiation pattern of a wire antenna structure on a Hummer vehicle is characterized and the effect of the platform is discussed. Finally, the path loss between monopole antennas mounted on the back of three collocated Hummer vehicles is determined and the interference patterns in a cross section through the vehicles are visualized.

II. CONCEPT OF THE HYBRID METHOD

Based on two antennas mounted on a vehicle as shown in Fig. 1, the concept of the hybrid MoM/FDTD technique [6] is illustrated. According to Fig. 1, the entire structure is par-

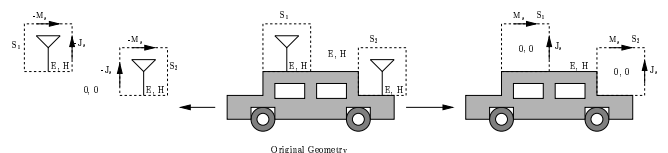

Figure 1: Decomposition of the original problem into sub-geometries modeled by MoM and FDTD.

tioned into sub-domains in order to solve them separately with either MoM [5] or FDTD [7]. In this problem, the antennas realized either as wire networks or printed structures and the vehicle as the platform are solved with the MoM and FDTD method, respectively. To invoke the Schelkunoff principle [6], Huygens surfaces are placed around the antennas. Three coupled equivalent problems are established where the

antennas are modeled by the MoM and the vehicle representing a fully 3D object with the FDTD method. The solution in the two sub-domains is equivalent to the original electromagnetic problem inside the enclosure of S_1 and S_2 and solution excluding the enclosures of the antennas is equivalent to the original problem outside of S_1 and S_2 as shown in Figure 1. To achieve a vanishing field outside the boundaries, electric and magnetic surface currents J_s and M_s have to be imposed on S_1 and S_2 , where $J_s = n \times H$ and $M_s = E \times n$ and vice versa. Because the fields on the Huygens surfaces of the original electromagnetic problem are not available and a brute solution of the coupled system is impossible, an iterative procedure is applied to approach the original field values in the entire domain.

For a performance evaluation of the hybrid MoM/FDTD method, a 3 m long dipole antenna inclined 21.8 degrees to the vertical was analyzed at 50 MHz in free space as an example. Fig. 2 shows the Huygens' surfaces enclosing the dipole antenna, which is embedded in a FDTD grid with a cell size of 0.3 m. A gap source in the center excites the dipole with

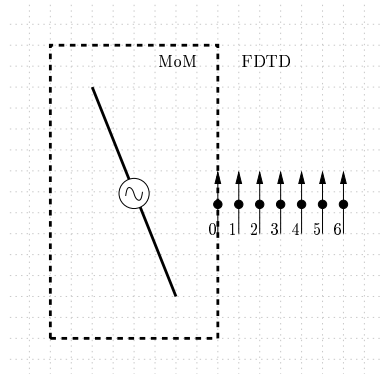

Figure 2: Hybrid approach for a half-wavelength dipole - electric field is observed at seven points.

1 V and the current distribution in the wire is approximated with 12 rooftop functions in the MoM. The electric field is observed at seven grid points according to Fig. 2 and the results obtained with the hybrid method are compared to the pure MoM data. The magnitude and the phase for both methods are shown in Fig. 3 and 4. It has proven that the hybrid method and the pure MoM are in good agreement and that an error in magnitude and phase of less than 2.2 % and 6.5 % is achieved in the near field of the dipole for a cell size of $\lambda/20$, respectively. As a consequence, the excitation of the FDTD domain with equivalent surface currents on the boundaries leads to a very accurate image for the field distribution in the near field.

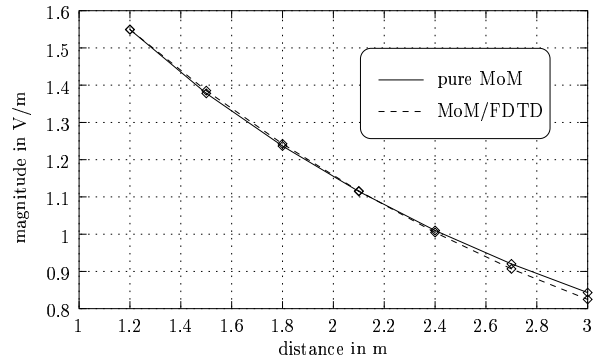

Figure 3: Magnitude of the electric field at seven observation points in the near-field zone (Fig. 2).

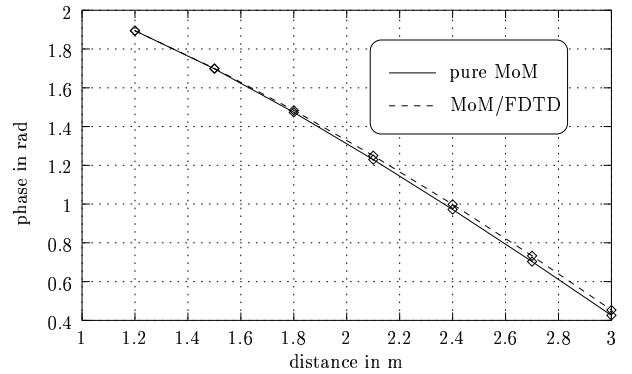

Figure 4: Phase of the electric field at seven observation points in the near-field zone. (Fig. 2).

III. RADIATION PATTERNS OF ANTENNAS ON VEHICLES

In this section, the radiation pattern of an antenna mounted on a military vehicle was modeled with the hybrid MoM/FDTD technique. According to Fig. 5 the antenna is located on the roof of a Hummer vehicle and is represented by equivalent surface currents in the FDTD method. The enclosure including the boundary surfaces are indicated in Fig. 5 as a box on top of the vehicle. In this case, the radiation diagram of a monopole inclined 21.8 degrees to the vertical is analyzed. The monopole under such an angle cannot be modeled efficiently with a pure FDTD approach unless the grid is locally refined in the region around the antenna. However, subgridding schemes in FDTD are well known for instabilities and reflections caused at the boundaries if a high refinement factor is applied. In addition to numerical problems and loss in sensitivity these techniques especially suffer from an enormous increase in computational effort. Since the antenna is placed on the roof of the vehicle, which is assumed as a perfectly conducting surface, the image principle has to be applied in the MoM to obtain zero tangential electric fields on the ground surface. Fig. 6 shows the antenna structure simu-

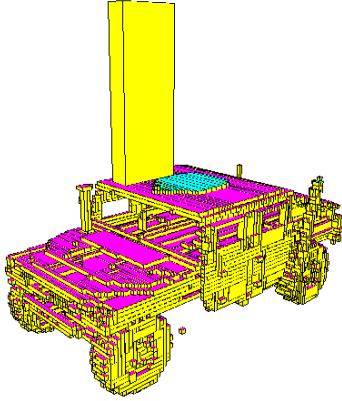

Figure 5: Antenna replaced by Huygens' surfaces.

lated with the MoM method. The equivalent surface currents

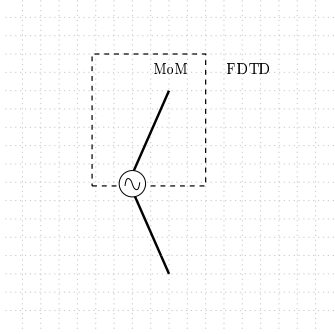

Figure 6: Slanted monopole antenna modeled with MoM.

are calculated on the boundaries indicated by the dashed lines in Fig. 6 at 50 MHz. A grid size of $\lambda/120$ was chosen for the subsequent FDTD simulation so that all electrically important details of the Hummer vehicle can be taken into account in the mesh. The magnitude of the magnetic field normal to the cross section is depicted in Fig. 7 after one iteration. Inside the subdomain enclosing the slanted monopole,

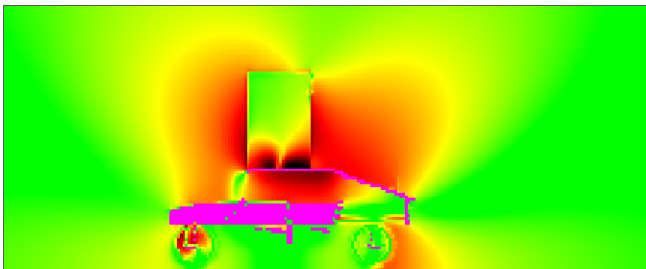

Figure 7: Magnitude of normal magnetic field.

only the scattered field is present whereas the total field is calculated everywhere else. Fig. 7 shows a small scattered field

inside the subdomain. However, areas with a higher scattered field concentrate at the edges of the Huygens' surface because the conducting ground surface - the roof of the vehicle - is truncated in the FDTD simulation and is assumed to be infinite in the MoM simulation. Consequently, a fast convergence is achieved and only a few iterations are required in the hybrid procedure since the current distribution in the wire is not affected by the small backscattered field. Further, the effect of the slanted antenna on the roof of the Hummer can be observed clearly. A strong magnetic field in the near-field zone around the monopole forms two beams under an angle of around 45 degrees to the horizontal. Fig. 8 and Fig. 9 show the far field (E_{Θ}) of the slanted monopole mounted on the Hummer vehicle in the E- and H-plane. Compared to a vertical monopole over an electric conducting surface the antenna also radiates vertically and a fluctuation of less than 6 dB is observed both in the E- and H-plane so that this configuration almost represents a quasi homogenous source due to the electromagnetic interference with the vehicle.

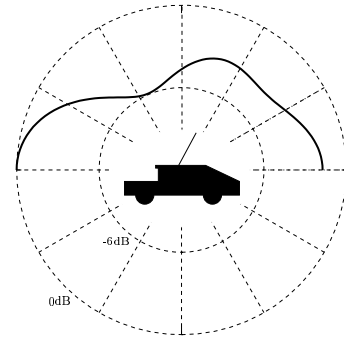

Figure 8: Radiation pattern (E-plane).

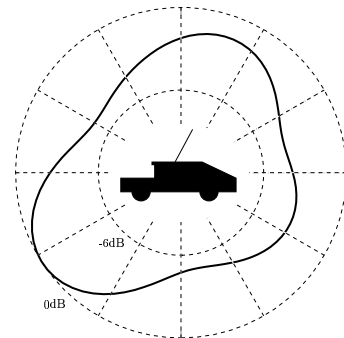

Figure 9: Radiation pattern (H-plane).

IV. PATH LOSS BETWEEN COLLOCATED VEHICLES

In the previous section, the impact of single vehicular platform on the radiation pattern was studied. In a second example, the path loss between two antennas on collocated Hum-

mer vehicles are calculated according to Fig. 10. In this case, the receiving antenna is placed in the near field zone of the other antenna, which requires a rigorous hybrid full wave approach. The electromagnetic analysis can solve cross talk issues between two antennas, which may corrupt the receiver's performance if the power level of the parasitic signal at the input stage exceeds the critical threshold. Especially problems are encountered with the code division multiple access (CDMA) technology where all transmitters operate at the same frequency. As a consequence, a receiver can be easily affected by a signal transmitted by a collocated vehicle and can drive the amplifier into saturation. In this case the path

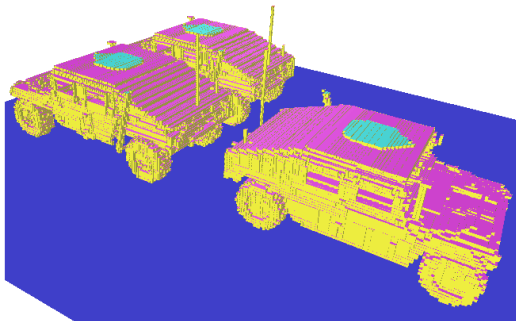

Figure 10: Co-site interference scenario.

loss between the monopole antennas on the back of the Hummer vehicles was determined. For the two vehicles facing each other, a path loss of 10.3 dB was obtained whereas the path loss between the two vehicles placed diagonal is 23.7 dB. Resonances cause a high attenuation between these two vehicles, which over 10 dB less than expected with the Friis formula as a rough approximation. The normal electric field in a cross section through the antenna mount is shown in Fig. 11. This diagram illustrates resonances in the scenario and

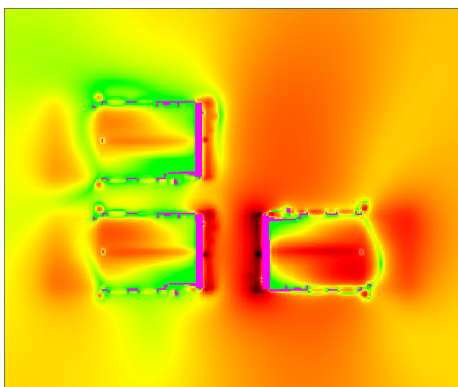

Figure 11: Magnitude of normal electric field.

gives a better understanding of the surprising results. To this end, the simulation of the antenna including the platform is

important for a prediction of the power levels in the receivers units.

V. CONCLUSION

In this paper, a hybrid MoM/FDTD method was applied to antenna systems on vehicular platforms. A wire antenna structure on a vehicle has been chosen for a feasibility study and has shown the potential of such a hybrid technique. This technique combines a powerful full-wave method in the frequency domain with a highly flexible method in the time-domain. The method of moments can accurately model arbitrary wire antenna structures or printed large-scale phased arrays whereas the FDTD method is predestinated to analyze the influence of the platform or scatterers, which are usually very complex three-dimensional objects. To this end, the hybrid full-wave approach delivers insight into the performance of multi-antenna systems and provides an efficient and highly accurate technique for a performance evaluation and design of radio systems. Further, the application of MPI techniques will also enable a fast optimization of printed large phase-array antenna systems under the influence of mobile platforms.

ACKNOWLEDGEMENT

This work was supported by the Naval Surface Warfare Center through a Phase I SBIR project for "Numerical Modeling of Complex Systems" (N00178-02-C-3059).

REFERENCES

- [1] GAVAN, J. and M.B. SHULMAN : *Effects on desensitization on Mobile Radio System Performance, Part I: Qualitative Analysis*. IEEE Trans. Vehicular Tech., 33(4):285–290, Nov. 1994.
- [2] GAVAN, J. and F. HANDLER : *Analysis, computation and mitigation of the interference to a remote receiver from two collocated vehicular transceivers*. IEEE Trans. Vehicular Tech., 45(3):431–442, Aug. 1996.
- [3] CONSTANTINE BALANIS: *Antenna Theory, Analysis and Design*. John Wiley & Sons, New York, 1982.
- [4] ROGER F. HARRINGTON: *Field Computation by Moment Methods*. IEEE Press, New York, 1993.
- [5] HISAMATSU NAKANO: *Helical and Spiral Antennas - A Numerical Approach*. Research Studies Press LTD., Letchworth, England, 1987.
- [6] Z. HUANG, K.R. DEMAREST AND R.G. PLUMB: *An FDTD/MoM Hybrid Technique for Modeling Complex Antennas in the Presence of Heterogeneous Grounds*. IEEE Trans. on Geoscience and Remote Sensing, 37(6):2692–2698, Nov. 1999.
- [7] K.S. YEE: *Numerical Solution of Initial Boundary Value Problems Involving Maxwell's Equation in Isotropic Media*. IEEE Trans. Antennas Propagation, 14(5):302–307, May 1966